

## ExtremeX/ExtremeX-S

### Infrared Cameras and Systems

[www.senspex.com](http://www.senspex.com)



The ExtremeX is a commanding solution to the long range thermal imaging requirements of the security surveillance sector. A rugged camera with extensive detection capabilities and the option of three or four fields of view, the ExtremeX/ExtremeX4 combines impressive performance with reliability and ease of use.

The ExtremeX has the most powerful detection capacity of the thermal imagers. It provides the ability to alternate rapidly among up to four focal lengths: 95 (X4 only), 250, 500, and 1000mm. Operating in the 3-5 $\mu$ m spectral region, the best choice for marine and high humidity environments, the ExtremeX incorporates advanced cooled photodetector technology in a 320 x 256 x InSb, 30 $\mu$ m pitch focal plane array, or optionally a 640 x 512, 15 $\mu$ m pitch focal plane array for maximum resolution (ExtremeX-S).

The proprietary environmentally sealed, nitrogen backfilled enclosure ensures simple secure installation and stability over variable temperatures and conditions. Remotely controlled and user friendly, the ExtremeX employs plug and play operation.

### FEATURES

- Auto & Manual Focus
- High Sensitivity Mode
- Dry Nitrogen Backfilled
- Remote Control Capability
- Optional Digital Video Output
- Cooled 3-5 $\mu$ m IR Detector Technology
- Three or Four Fields of View

Tri-Field: 0.55°, 1.1°, 2.2° (1000/500/250mm)

Quad-Field: 0.55°, 1.1°, 2.2°, 5.8°  
(1000/500/250/95mm)

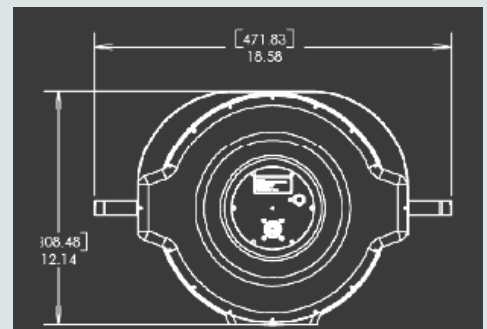
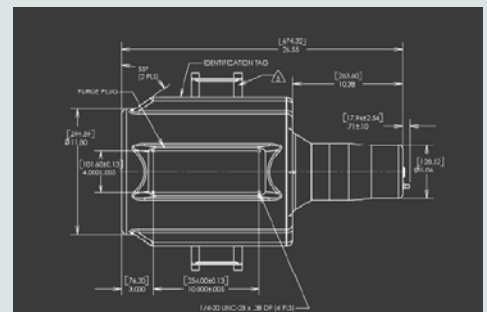

# ExtremeX/ExtremeX-S

## System Specifications

Part Number	23047M (Tri-Field) 23195M (Quad-Field)
Video Format	NTSC, PAL, or optional digital output
Serial Interface	RS-232/RS-422
Power Requirements	11-16 VDC, 18 Watts typical @ 25°C steady state (ExtremeX), 10.5—36 VDC, 30 Watts typical @ 25°C steady state (ExtremeX-S)
Environmental	Unit sealed and dry nitrogen backfilled, rate IP67 Front Element Defroster Operating Temperature Range: -32°C to +60°C Non-Operating Temperature Range: -40°C to +70°C
Controls	Controls available on a handheld pendant or through a PC via an RS-232/422 link
Mounting	¼-20 Tripod Interface AntiVibration Mount (optional)
Weight	<42 lbs. (19.1kg)
Length	<29.5" (75cm)

## Optical Characteristics

Spectral Range	3-5µm
Lens Type	Tri-Field of View, 250mm/500mm/1000mm or Quad-Field of View, 95mm/250mm/500mm/1000mm
f/#	4
Lens Features	Motorized Remote Operation Auto and Manual Focus Adjust Tri- or Quad-Field of View
Field of View	5.8° x 4.3° (Extra Wide—optional Quad-Field) 2.2° x 1.7° (Wide) 1.1° x 0.8° (Mid) 0.55° x 0.41° (Narrow)

## Sensor Specifications

ExtremeX Detector	320 x 256 Insb, FPA 30µm pitch
ExtremeX-S Detector	640 x 512 InSb, FPA 15µm pitch (add "Z" suffix to part number; see table below)
Spectral Band	3-5µm

## Construction of Part Numbers

Code	Featured Referenced Options	Example
Bn	Baud Rate (Default = 9600)	23047MB3
B1	4800	
B3	19200	
B4	38400	
B5	57600	
B6	115200	
D	Digital Video Option	23195MD
K	Sun Shield	23047MK
N	No BNC Video Output	23047MN
P	PAL Video Format	23195MP
Vnn	Paint Version	23047MV4
Z	640 x 480 Sensor Option	23195MZ

To construct Part Numbers, start with base code, add other desired options alphabetically, excepting that "P" must be last. Example: 23047MB4KP

# SENSPEX

APPLIED SCIENCE & TECHNOLOGY

9798 Coors Blvd NW, Building B, Albuquerque, NM 87114-6133  
505.891.0034 | [www.senspex.com](http://www.senspex.com)

Manufacturer reserves the right to change specifications to reflect latest changes in technology and improvements at any time without notice.  
Export is subject to US Government regulations.

